

Name: _____

Class: _____

13 - Sampling and reconstruction

Experiment 13 - Sampling and reconstruction

Preliminary discussion

So far, the experiments in this manual have concentrated on communications systems that transmit analog signals. However, digital transmission is fast replacing analog in commercial communications applications. There are several reasons for this including the ability of digital signals and systems to resist interference caused by electrical noise.

Many digital transmission systems have been devised and several are considered in later experiments. Whichever one is used, where the information to be transmitted (called the *message*) is an analog signal (like speech and music), it must be converted to digital first. This involves *sampling* which requires that the analog signal's voltage be measured at regular intervals.

Figure 1a below shows a pure sinewave for the message. Beneath the message is the digital *sampling signal* used to tell the sampling circuit when to measure the message. Beneath that is the result of "naturally" sampling the message at the rate set by the sampling signal. This type of sampling is "natural" because, during the time that the analog signal is measured, any change in its voltage is measured too. For some digital systems, a changing sample is unacceptable. Figure 1b shows an alternative system where the sample's size is fixed at the instant that the signal measured. This is known as a *sample-and-hold* scheme (and is also referred to as *pulse amplitude modulation*).

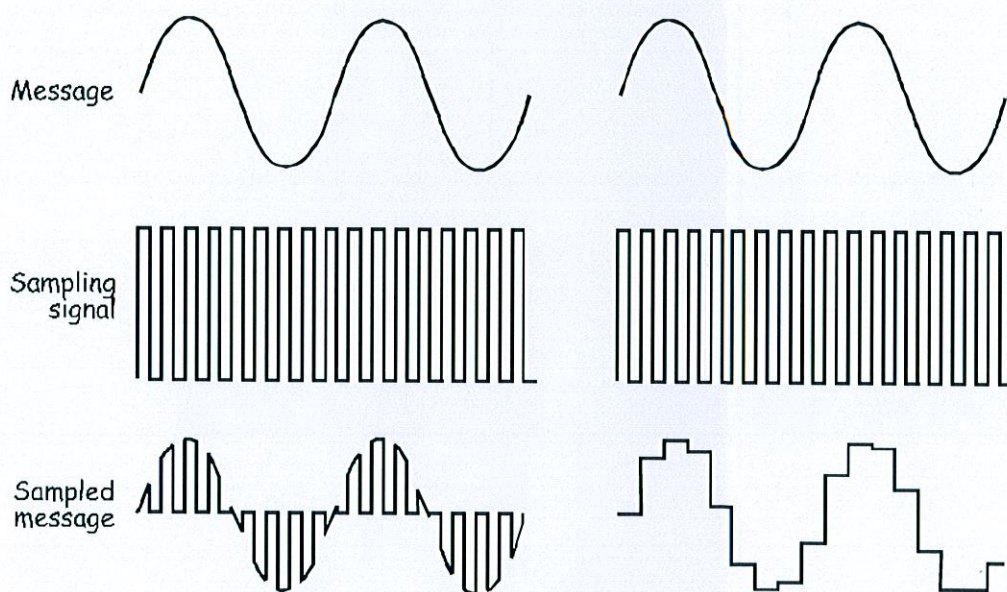

Figure 1a

Figure 1b

Regardless of the sampling method used, by definition it captures only pieces of the message. So, how can the sampled signal be used to recover the whole message? This question can be answered by considering the mathematical model that defines the sampled signal:

$$\text{Sampled message} = \text{the sampling signal} \times \text{the message}$$

As you can see, sampling is actually the multiplication of the message with the sampling signal. And, as the sampling signal is a digital signal which is actually made up of a DC voltage and many sinewaves (the fundamental and its harmonics) the equation can be rewritten as:

$$\text{Sampled message} = (\text{DC} + \text{fundamental} + \text{harmonics}) \times \text{message}$$

When the message is a simple sinewave (like in Figure 1) the equation's solution (which necessarily involves some trigonometry that is not shown here) tells us that the sampled signal consists of:

- A sinewave at the same frequency as the message
- A pair of sinewaves that are the sum and difference of the fundamental and message frequencies
- Many other pairs of sinewaves that are the sum and difference of the sampling signals' harmonics and the message

This ends up being a lot of sinewaves but one of them has the same frequency as the message. So, to recover the message, all that need be done is to pass the sampled signal through a low-pass filter. As its name implies, this type of filter lets lower frequency signals through but rejects higher frequency signals.

That said, for this to work correctly, there's a small catch which is discussed in Part E of the experiment.

The experiment

For this experiment you'll use the Emona DATEx to sample a message using natural sampling then a sample-and-hold scheme. You'll then examine the sampled message in the frequency domain using the NI ELVIS II Dynamic Signal Analyzer. Finally, you'll reconstruct the message from the sampled signal and examine the effect of a problem called *aliasing*.

It should take you about 50 minutes to complete this experiment.

Equipment

- Personal computer with appropriate software installed
- NI ELVIS II plus USB cable and power pack
- Emona DATEx experimental add-in module
- Two BNC to 2mm banana-plug leads
- Assorted 2mm banana-plug patch leads

Part A - Sampling a simple message

The Emona DATEx has a Dual Analog Switch module that has been designed for sampling. This part of the experiment lets you use the module to sample a simple message using two techniques.

Procedure

1. Ensure that the NI ELVIS II power switch at the back of the unit is off.
2. Carefully plug the Emona DATEx experimental add-in module into the NI ELVIS II.
3. Set the *Control Mode* switch on the DATEx module (top right corner) to *PC Control*.
4. Connect the NI ELVIS II to the PC using the USB cable.

Note: This may already have been done for you.

5. Turn on the NI ELVIS II power switch at the rear of the unit then turn on its *Prototyping Board Power* switch at the top right corner near the power indicator.
6. Turn on the PC and let it boot-up.
7. Launch the NI ELVISmx software.



Ask the instructor to check your work before continuing.

8. Connect the set-up shown in Figure 2 below.

Note: Insert the black plugs of the oscilloscope leads into a ground (*GND*) socket.

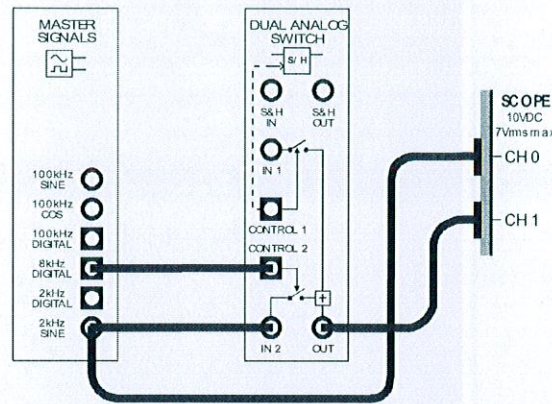

Figure 2

This set-up can be represented by the block diagram in Figure 3 below. It uses an electronically controlled switch to connect the message signal (the *2kHz SINE* output from the Master Signals module) to the output. The switch is opened and closed by the *8kHz DIGITAL* output of the Master Signals module.

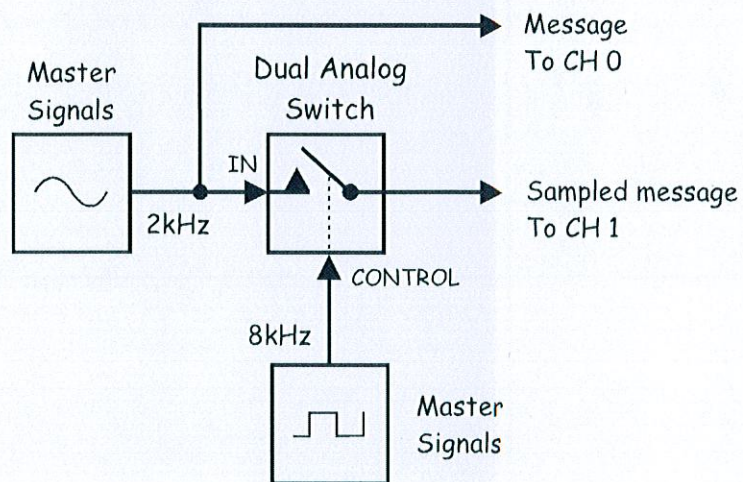

Figure 3

9. Launch and run the NI ELVIS II Oscilloscope VI.
10. Set up the scope per the procedure in Experiment 1 (page 1-12) with the following change:
 - *Timebase* control to the $100\mu\text{s}/\text{div}$ position instead of $500\mu\text{s}/\text{div}$
11. Adjust the scope's *Timebase* control to view two or so cycles of the Master Signals module's 2kHz *SINE* output.
12. Activate the scope's Channel 1 input by (by checking the Channel 1 *Enabled* box) to observe the sampled message out of the Dual Analog Switch module as well as the message.

Tip: To see the two waveforms clearly, you may need to adjust the scope so that the two signals are not overlaid.

13. Draw the two waveforms to scale in the space provided on the next page leaving room to draw a third waveform.

Tip: Draw the message signal in the upper third of the graph and the sampled signal in the middle third.

Question 1

What type of sampling is this an example of?

- Natural
- Sample-and-hold

Question 2

What two features of the sampled signal confirm this?

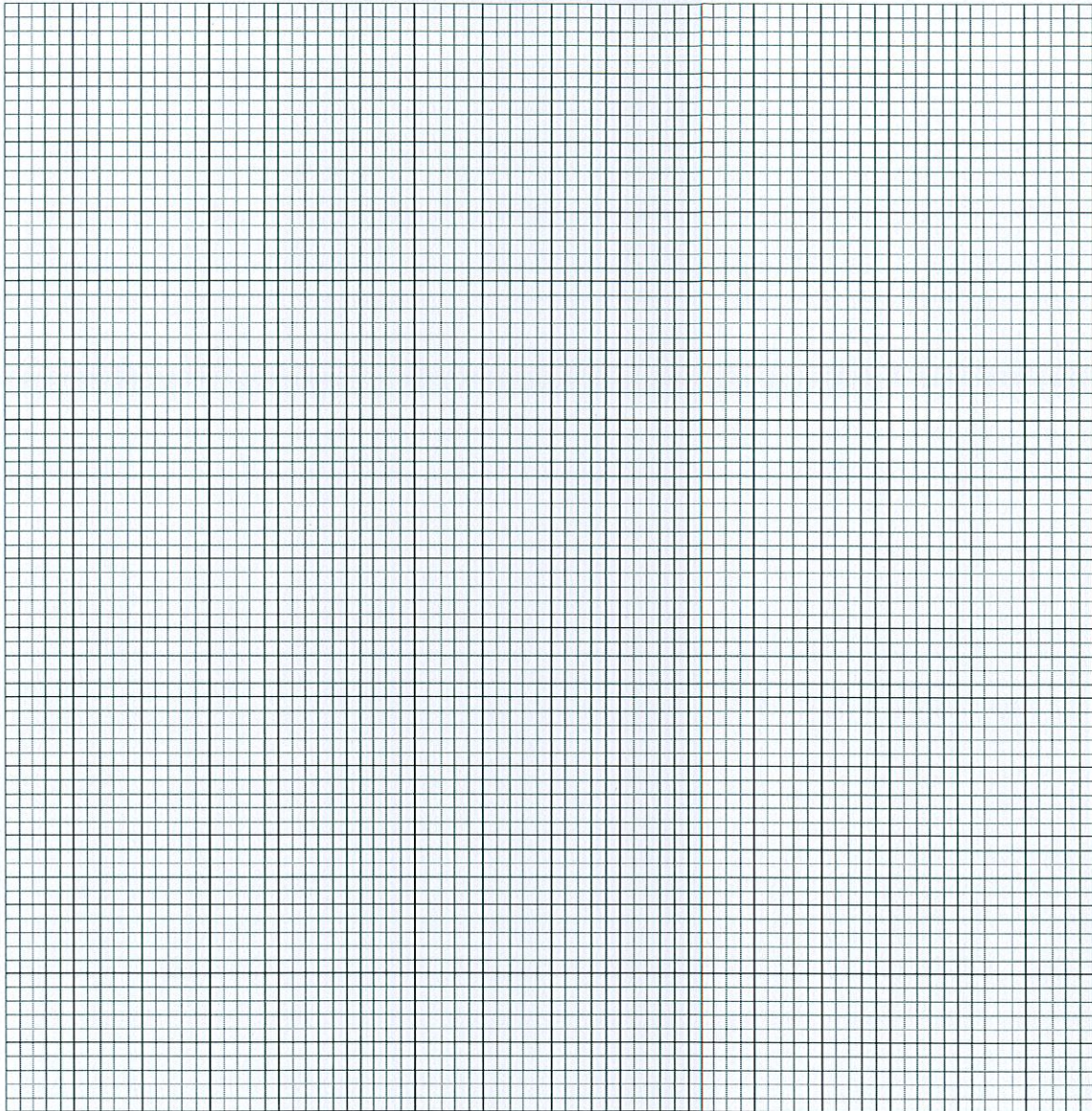

Ask the instructor to check
your work before continuing.

14. Modify the set-up as shown in Figure 4 below.

Before you do...

The set-up in Figure 4 below builds on the set-up that you've already wired so don't pull it apart. To highlight the changes that we want you to make, we've shown your existing wiring as dotted lines.

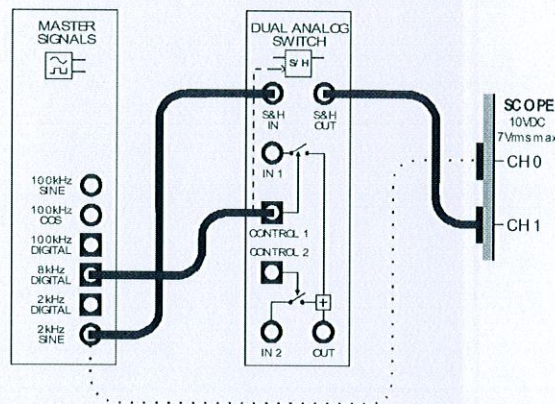

Figure 4

This set-up can be represented by the block diagram in Figure 5 on the next page. The electronically controlled switch in the original set-up has been substituted for a sample-and-hold circuit. However, the message and sampling signals remain the same (that is, a 2kHz sinewave and an 8kHz pulse train).

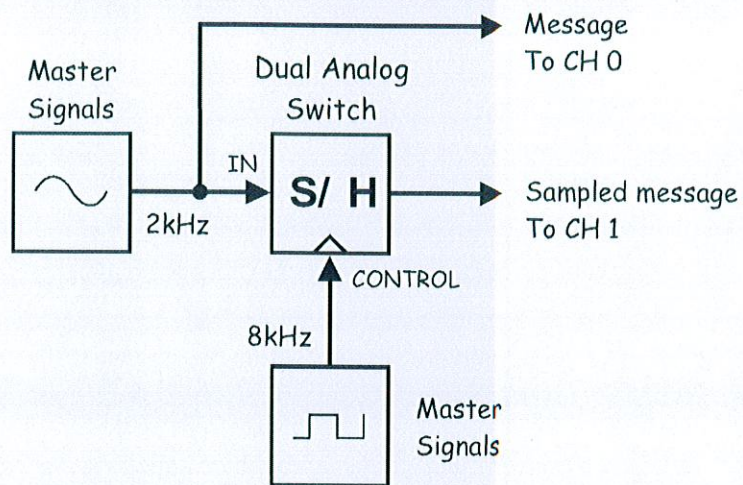

Figure 5

15. Draw the new sampled message to scale in the space that you left on the graph paper.

Question 3

What two features of the sampled signal confirm that the set-up models the sample-and-hold scheme?



Ask the instructor to check your work before continuing.

Part B - Sampling speech

This experiment has sampled a 2kHz sinewave. However, the message in commercial digital communications systems is much more likely to be speech and music. The next part of the experiment lets you see what a sampled speech signal looks like.

16. Disconnect the plugs to the Master Signals module's 2kHz SINE output.
17. Connect them to the Speech module's output as shown in Figure 6 below.

Remember: Dotted lines show leads already in place.

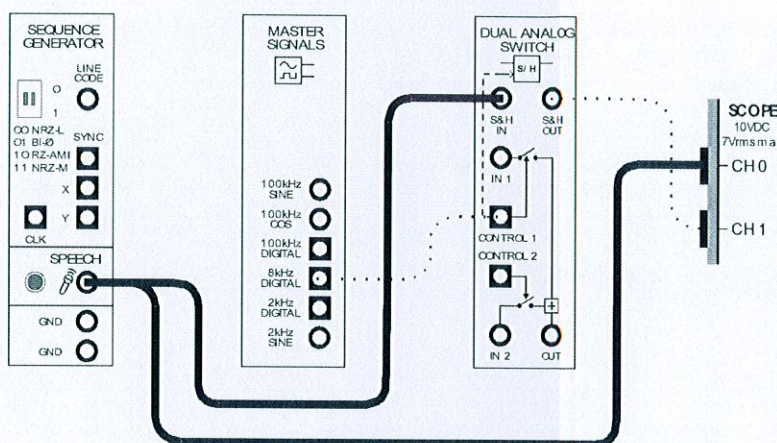

Figure 6

18. Set the scope's *Timebase* control to the $500\mu\text{s}/\text{div}$ position.
19. Hum and talk into the microphone while watching the scope's display.



Ask the instructor to check your work before continuing.

Part C - Observations and measurements of the sampled message in the frequency domain

Recall that the sampled message is made up of many sinewaves. Importantly, for every sinewave in the original message, there's a sinewave in the sampled message at the same frequency. This can be proven using the NI ELVIS II Dynamic Signal Analyzer. This device performs a mathematical analysis called *Fast Fourier Transform* (FFT) that allows the individual sinewaves that make up a complex waveform to be shown separately on a *frequency-domain* graph. The next part of the experiment lets you observe the sampled message in the frequency domain.

20. Return the scope's *Timebase* control to the $100\mu\text{s}/\text{div}$ position.

21. Disconnect the plugs to the Speech module's output and reconnect them to the Master Signals module's 2kHz SINE output.

Note: The scope should now display the waveform that you drew for Step 15.

22. Suspend the scope VI's operation by clicking on its *Stop* control once.

Note: The scope's display should freeze and its hardware has been deactivated. This is a necessary step as the scope and signal analyzer share hardware resources and so they cannot be operated simultaneously.

23. Launch the NI ELVIS II Dynamic Signal Analyzer VI.

Note: If the signal analyzer's VI has launched successfully, the instrument's window will be visible (see Figure 7).

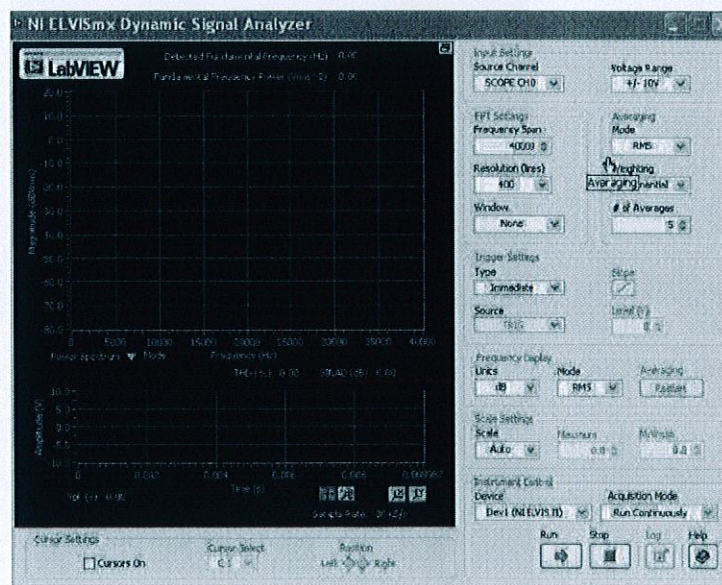

Figure 7

24. Adjust the Signal Analyzer's controls as follows:

Input Settings

- *Source Channel* to *SCOPE CH 1*
- *Voltage Range* to $\pm 10V$

FFT Settings

- *Frequency Span* to *40,000*
- *Resolution* to *400*
- *Window* to *7 Term B-Harris*

Averaging

- *Mode* to *RMS*
- *Weighting* to *Exponential*
- *# of Averages* to *3*

Trigger Settings

- *Type* to *Edge*

Frequency Display

- *Units* to *dB* (for now)
- *Mode* to *RMS*
- *Scale* to *Auto*
- *Cursors On* box unchecked (for now)

25. Click on the signal analyzer's *Run* control.

Note: If the Signal Analyzer VI has been set up correctly, its display should look like Figure 8 below.

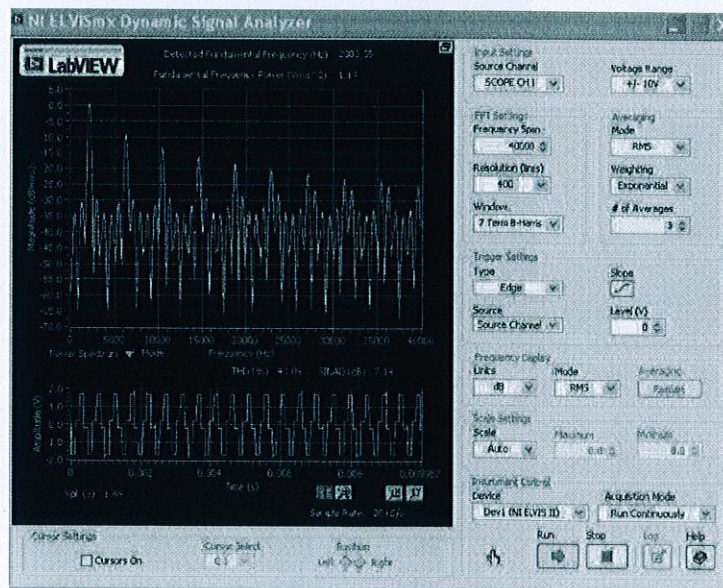

Figure 8

If you've not attempted Experiment 7, the signal analyzer's display may need a little explaining here. There are actually two displays, a large one on top and a much smaller one underneath. The smaller one is a time domain representation of the input (in other words, the display is a scope).

The larger of the two displays is the frequency domain representation of the complex waveform on its input (the sampled message). The humps represent the sinewaves and, as you can see, the sampled message consists of many of them. As an aside, these humps should just be simple straight lines, however, the practical implementation of FFT is not as precise as the theoretical expectation.

If you have done Experiment 7, go directly to Step 33 on the next page.

26. Activate the signal analyzer's cursors by checking (that is, ticking) *Cursors On* box.

Note: When you do, green horizontal and vertical lines should appear on the signal analyzer's frequency domain display.

The NI ELVIS II Dynamic Signal Analyzer has two cursors *C1* and *C2* that default to the left most side of the display when the signal analyzer's VI is launched. They're repositioned by "grabbing" their vertical lines with the mouse and moving the mouse left or right.

27. Use the mouse to grab and move the vertical line of cursor *C1*.

Note: As you do, notice that cursor *C1* moves along the signal analyzer's trace and that the vertical and horizontal lines move so that they always intersect at *C1*.

28. Repeat Step 27 for cursor *C2*.

Note: Fine control over the cursors' position is obtained by using the cursor's *Position* control in the *Cursor Settings* area (below the display).

The NI ELVIS II Dynamic Signal Analyzer includes a tool that measures the *difference* in magnitude and frequency between the two cursors. This information is displayed in green between the upper and lower parts of the display.

29. Move the cursors while watching the measurement readout to observe the effect.

30. Position the cursors so that they're on top of each other and note the measurement.

Note: When you do, the measurement of difference in magnitude and frequency should both be zero.

Usefully, when one of the cursors is moved to the extreme left of the display, its position on the X-axis is zero. This means that the cursor is sitting on 0Hz. It also means that the measurement readout gives an absolute value of frequency for the other cursor. This makes sense when you think about it because the readout gives the difference in frequency between the two cursors but one of them is zero.

31. Move $C2$ to the extreme left of the display.
32. Align $C1$ with the highest point of any one of the humps.

Note: The readout will now be showing you the frequency of the sinewave that the hump represents.

Recall that the message signal being sampled is a 2kHz sinewave. This means that there should also be a 2kHz sinewave in the sampled message.

33. Use the signal analyzer's $C1$ cursor to locate sinewave in the sampled message that has the same the frequency as the original message.



Ask the instructor to check your work before continuing.

As discussed earlier, the frequency of all of the sinewaves in the sampled message can be mathematically predicted. Recall that digital signals like the sampling circuit's clock signal are made up out of a DC voltage and many sinewaves (the fundamental and harmonics). As this is a sample-and-hold sampling scheme, the digital signal functions as a series of pulses rather than a squarewave. This means that the sampled signal's spectral composition consists of a DC voltage, a fundamental and both even and odd whole number multiples of the fundamental. For example, the 8kHz sampling rate of your set-up consists of a DC voltage, an 8kHz sinewave (f_s), a 16kHz sinewave ($2f_s$), a 24kHz sinewave ($3f_s$) and so on.

The multiplication of the sampling signal's DC component with the sinewave message gives a sinewave at the same frequency as the message and you have just located this in the sampled signal's spectrum.

The multiplication of the sampling signal's fundamental with the sinewave message gives a pair of sinewaves equal to the fundamental frequency plus and minus the message frequency. That is, it gives a 6kHz sinewave (8kHz - 2kHz) and a 10kHz sinewave (8kHz + 2kHz).

In addition to this, the multiplication of the sampling signal's harmonics with the sinewave message gives pairs of sinewaves equal to the harmonics' frequency plus and minus the message frequency. That is, the signal also consists of sinewaves at the following frequencies: 14kHz (16kHz - 2kHz), 18kHz (16kHz + 2kHz), 22kHz (24kHz - 2kHz), 26kHz (24kHz + 2kHz) and so on.

All of these sum and difference sinewaves in the sampled signal are appropriately known as *aliases*.

34. Use the signal analyzer's *C1* cursor to locate and measure the exact frequency of the sampled signal's first six aliases. Record your measurements in Table 1 below.

Tip: Their frequencies will be close to those listed above.

Table 1

Alias 1		Alias 4	
Alias 2		Alias 5	
Alias 3		Alias 6	



Ask the instructor to check your work before continuing.

Why aren't the alias frequencies exactly as predicted?

You will have notice that the measured frequencies of your aliases don't exactly match the theoretically predicted values. This is not a flaw in the theory. To explain, the Emona DATEx has been designed so that the signals out of the Master Signals module are synchronised. This is a necessary condition for the implementation of many of the modulation schemes in this manual. To achieve this synchronisation, the 8kHz and 2kHz signals are derived from a 100kHz master crystal oscillator. As a consequence, their frequencies are actually 8.3kHz and 2.08kHz.

Part D - Reconstructing a sampled message

Now that you have proven that the sampled message consists of a sinewave at the original message frequency, it's easy to understand how a low-pass filter can be used to "reconstruct" the original message. The LPF can pick-out the sinewave at the original message frequency and reject the other higher frequency sinewaves. The next part of the experiment lets you do this.

35. Suspend the Signal Analyzer VI's operation by clicking on its *Stop* control once.

Note: The analyzer's display should freeze.

36. Restart the scope's VI by clicking its *Run* control once.

37. Launch the DATEx soft front-panel (SFP).

38. Check you now have soft control over the DATEx by activating the PCM Encoder module's soft *PDM/TDM* control on the DATEx SFP.

Note: If your set-up is working correctly, the PCM Decoder module's LED on the DATEx board should turn on and off.

39. Locate the Tuneable Low-pass Filter module on the DATEx SFP and set its soft *Gain* control to about the middle of its travel.
40. Turn the Tuneable Low-pass Filter module's soft *Cut-off Frequency Adjust* control fully anti-clockwise.
41. Modify the set-up as shown in Figure 9 below.

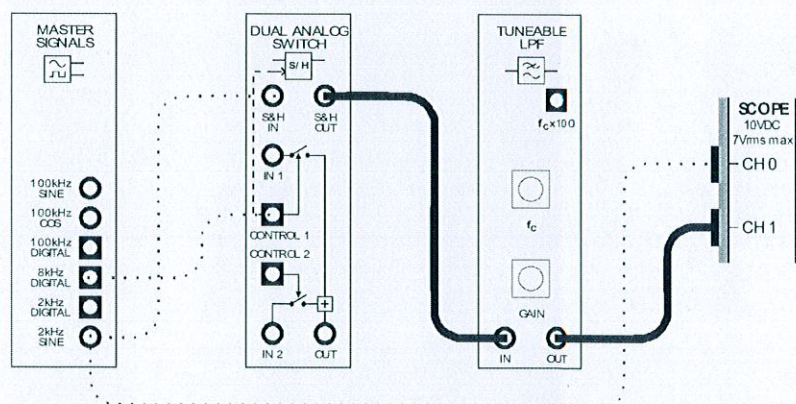

Figure 9

The set-up in Figure 9 can be represented by the block diagram in Figure 10 below. The Tuneable Low-pass Filter module is used to recover the message. The filter is said to be "tuneable" because the point at which frequencies are rejected (called the *cut-off frequency*) is adjustable.

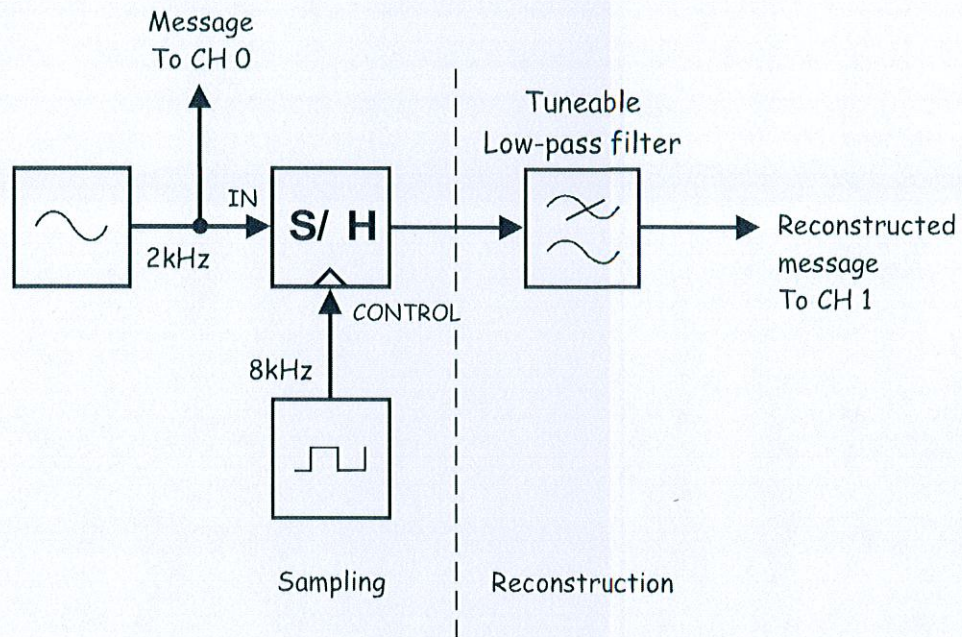

Figure 10

At this point there should be nothing out of the Tuneable Low-pass Filter module. This is because it has been set to reject almost all frequencies, even the message. However, the cut-off frequency can be increased by turning the module's *Cut-off Frequency Adjust* control clockwise.

42. Slowly turn the Tuneable Low-pass Filter module's soft *Cut-off Frequency* control clockwise and stop when the message signal has been reconstructed and is roughly in phase with the original message.



Ask the instructor to check your work before continuing.